

Innovation

Commercial Tankless Water Heaters



INN 600N • INN 800N • INN 1060N • INN 1350N

Hot Water on Demand without the Tank

The AERCO Innovation commercial tankless water heater provides safe, reliable hot water on demand without the need for any significant storage volume to buffer load change and provide stable hot water temperatures. Due to its unique tankless design, the Innovation has the smallest footprint of any commercial size application. It's easy to install, simple to service and cost effective eliminating the need for expensive storage tanks, mixing valves and tank circulators.

Key Features and Benefits

- Long-lasting and highly reliable AERguard™ stainless steel helical firetube heat exchanger assembly is thermal shockproof and scale resistant
- 2-3x warranty protection vs. the competition
- Precise temperature control $\pm 4^{\circ}\text{F}$ due to dynamic feed-forward sensing and unmatched turndown
- Low operating, maintenance and installation costs
- High efficiency with lower set point of 124°F
- Compact footprint creates more available space
- 1/3 the standby losses compared to conventional tank-type heaters
- Easy installation and venting versatility; direct/conventional venting with PVC, CPVC, Polypropylene or AL29-4C materials
- Low NOx and CO emissions
- Able to daisy-chain multiple units for applications over 1000 MBH
- Eliminates need for mixing valves, tank circulators, storage tanks
- Available sizes: 625, 800, 1060, 1350 MBH

State-of-the-Art Technology

Innovation water heaters utilize state-of-the-art technology to easily meet highly diverse, demanding commercial and industrial hot water requirements in a compact and reliable condensing design. Its durable, high-efficient, helical wound firetube heat exchanger is time-tested to be impervious to thermal stress for extended life. Enhanced waterside flow distribution maintains constant minimum velocities above 4 ft/sec across the heat exchanger. This keeps solids in suspension and greatly reduces scale dropout to maintain high efficiency and long life. The all stainless steel construction maximizes longevity in the condensing application and won't need fireside cleaning. The corrugated tubes increase effective heat transfer surface area for optimal thermal efficiencies.

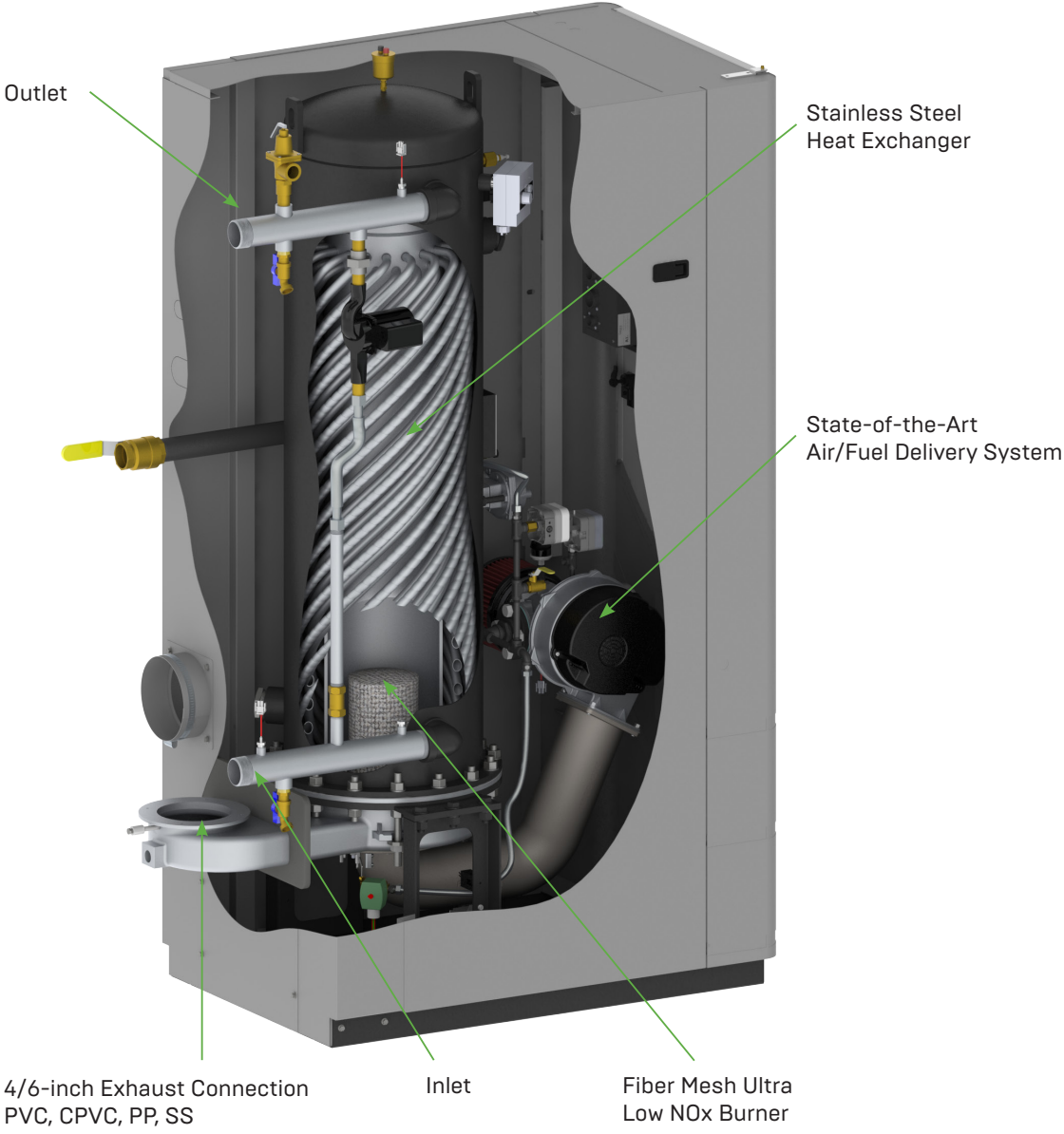

The Benefits of Tankless Water Heaters

Tankless water heating systems help deliver the best possible ROI compared to their typical storage tank counterparts. Not only do they lower costs on installation and operation, but they save a tremendous amount of space for the facility due to the elimination of big storage tanks and ability to use common venting. Innovation also provides a safer environment for customers and outlives tanked competitors by 5-10 years.

Lower Installation, Maintenance and Operational Costs

Venting is one of the most expensive installation items. AERCO's Innovation allows for common venting with different sized units, as well as in combination with Benchmark boilers. This can significantly reduce the number of vent runs and wall/roof penetrations, which lowers overall installation costs. Costs are lowered further because there's no need to purchase expensive storage tanks, circulators, and mixing valves. Operational costs are similarly decreased due to high efficiency, high turndown and reduced standby losses. With no need for hot water storage, less fuel is burned thereby increasing energy savings.

Space-Saving Design

The Innovation is delivered as a single, fully assembled unit. Its small, doorway-sized footprint and quiet operation make it ideal for both new construction and retrofit applications. The unit's compact size allows it to be easily moved in and out of a mechanical room whether it's located in a cramped basement or in the penthouse of a 25-story building, eliminating the costs of tearing down walls or hoisting via helicopter. More available room can be used to generate income instead of unnecessarily storing water.

The Safer Water Heater

Stored water in a tank must be maintained at a hot temperature of 140°F in order to prevent Legionella bacteria, which means the water needs to be heated up only to be cooled down for consumption. However, the tankless design of the Innovation water heaters allows the system to operate with a set point of 124°F – saving energy and reducing the risk of scalding while eliminating the need for costly mixing valves. Because water volume is kept to a minimum and continual circulation is maintained through the unit, the Innovation mitigates the risk of Legionella bacteria growth.

Longer Life Cycle

With an expected life of more than 20 years, the Innovation lasts two to three times longer than a tanked heating system, which typically needs to be replaced every five to 10 years because storage tanks can be prone to rust, system failure and water damage.

Sleek Design that Saves Space and Costs

Four Innovations are 1/3 the footprint of four typical storage tank water heaters

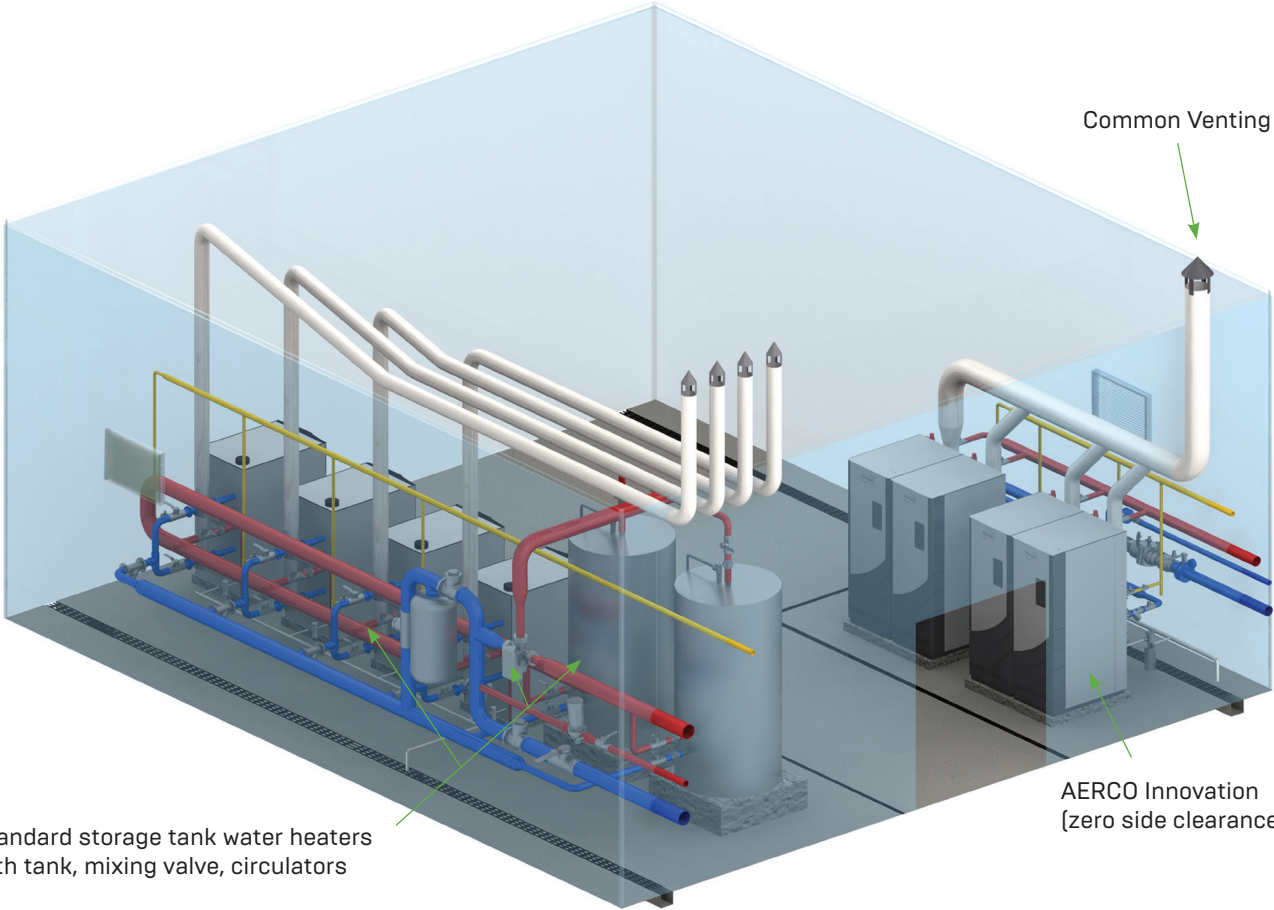

Standard storage tank water heaters with tank, mixing valve, circulators

AERCO Innovation (zero side clearance)

Advanced Design

Dynamic Load Anticipator

Further improving the efficiency of Innovation is AERCO's Dynamic Load Anticipator, an advanced control system that helps maintain precise modulation of the high turndown air/fuel delivery system. Field-proven for more than 60 years, dynamic feed-forward and feed-back sensors monitor inlet flow via the proportional change in mixed temperatures due to variations in the flow. The system's controls fire the unit to accurately match load requirements and produce tight $\pm 4^{\circ}\text{F}$ outlet temperature control.

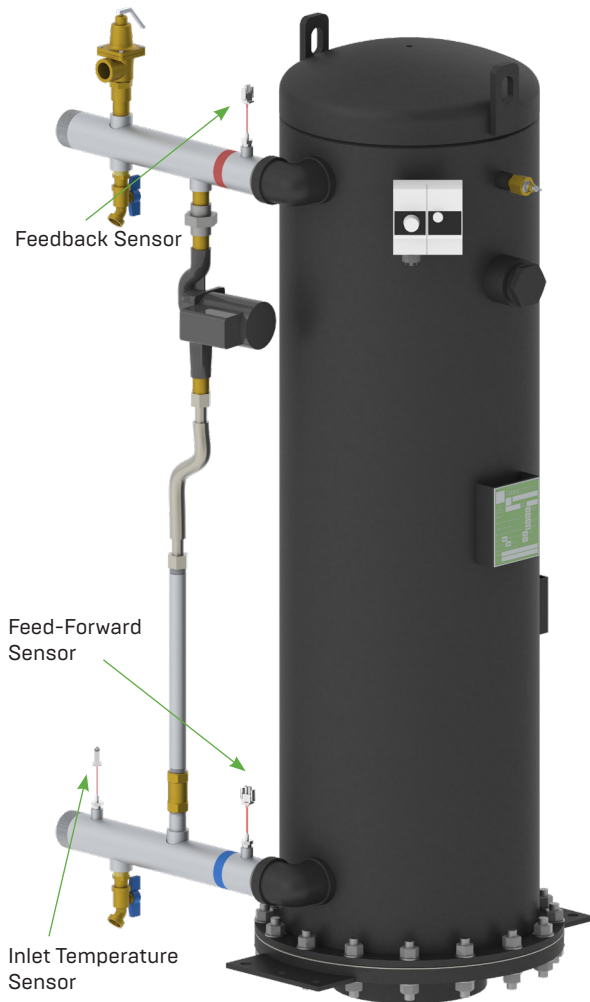

High Turndown Air/Fuel Valve Delivery System

Innovation's high turndown air/fuel delivery system consists of AERCO's patented fully modulating air/fuel valve, VFD driven premix blower, and fiber mesh radiant burner. The system guarantees safe, stable, reliable and efficient combustion with the lowest NO_x and CO emissions, as well as eliminates wasted fuel and reduces operating costs, making Innovation the smart choice for "green" designs.

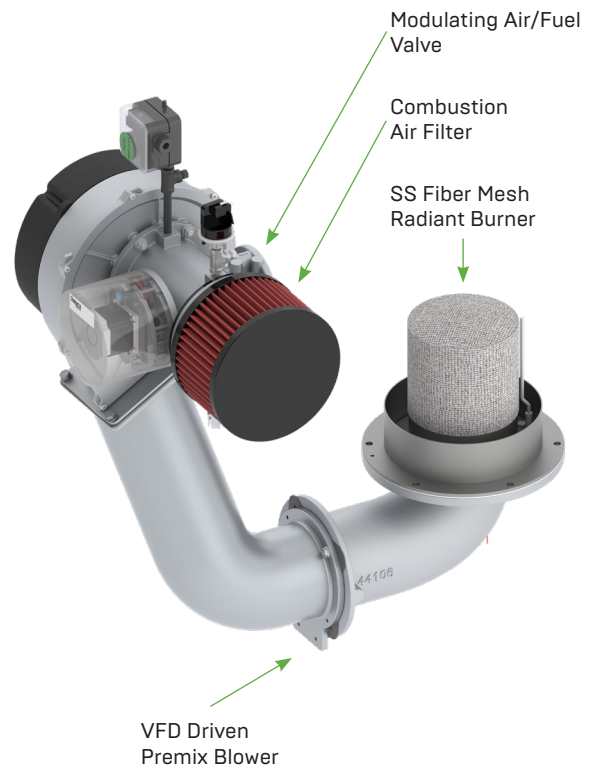

Edge Controller with Water Heater Management

AERCO's Innovation features the Edge [i] Controller which combines temperature and operating controls, combustion safeguards and fault enunciator functions on a touchscreen, ensuring fail-safe heater operation if the external building controls fail.

AERCO's Water Heater Management system (WHM) comes standard onboard the Edge [i] Controller. WHM is designed to efficiently sequence up to sixteen water heaters on the same system to meet load requirements and ensure all water heaters in the system operate at maximum efficiency. It monitors the fire rate of all water heater sequences by opening or closing the motorized valve, as required, to meet hot water demand.

The result is the most energy-efficient and reliable water heating system design available. Only those units required to meet load are operating. Units in standby do not needlessly cycle to maintain set point – reducing system standby losses and unit wear to the bare minimum. Compared to a conventional storage system which requires 125 gallons of storage for every 500 MBH input, an Innovation system truly provides reliable domestic hot water on demand in the smallest possible energy footprint. All of which significantly reduces maintenance and operating costs, while increasing Return on Investment.

Benefits:

- Optimizes operating efficiencies at all load conditions
- Virtually eliminates standby losses
- Increases system reliability through reduced cycling
- Accurately tracks daily domestic hot water demands

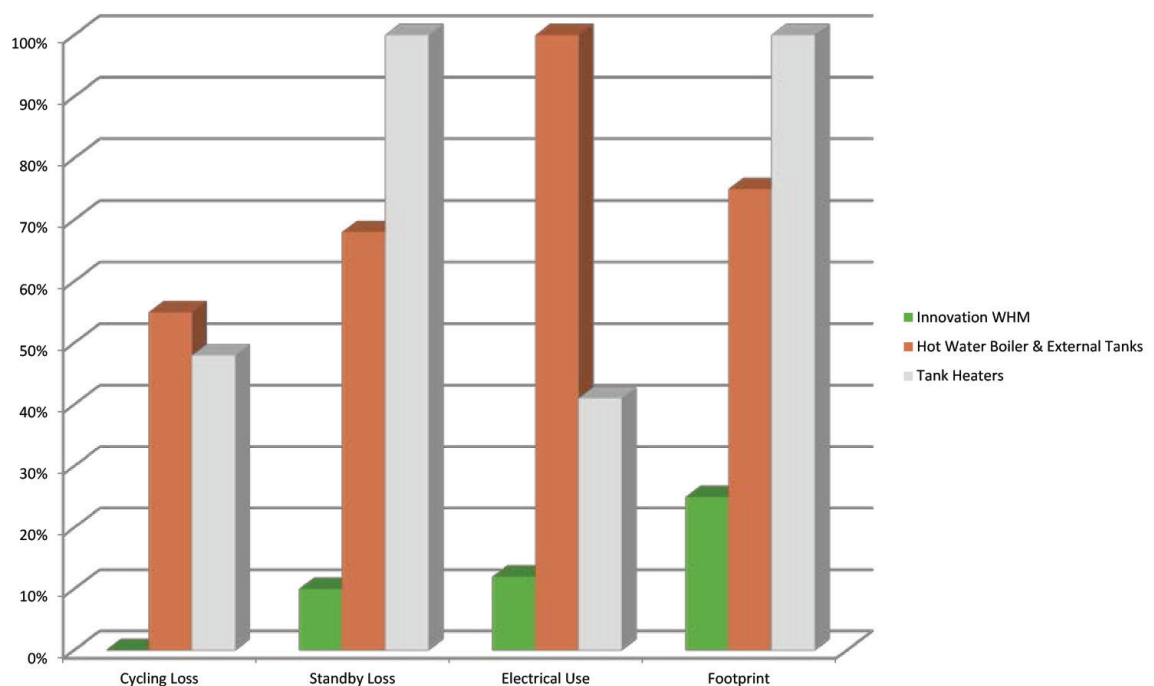

Environmental Stewards



High efficiency Innovation water heaters are perfect for green building designs satisfying stringent requirements associated with environmentally-conscious facilities, and helping to facilitate LEED certifications.

Designed for Green Building (LEED credits)

- Site Development (maximize open space): compact footprint with flexible venting
- Water Efficient Landscaping: condensate can be recovered (neutralization required) and used for irrigation or other gray water applications
- Optimize Energy Performance: maximizes operating efficiency through Water Heater Management and high turndown (virtually eliminating standby losses)
- Low Emitting Materials (Adhesives and Sealants): incorporates Green Seal Standard GS-36 and Green Guard® compliant, Volatile Organic Compounds
- Low Emitting Materials (Paints and Coatings): uses corrosion and oxidation preventing paints, Green Seal Standard GS-03 compliant, Volatile Organic Compounds
- Indoor Chemical and Pollutant Source Control: ducted combustion capability eliminates the need for louvers or damper systems that can potentially bring chemicals/pollutants from outside
- Innovation in Design: tankless, compact footprint and turndown minimize cycling

Reduced Energy Consumption

The Innovation is constantly condensing (heating cold inlet water vs recovering hot water from a storage tank) and uses less electrical power (no circulator pumps).

Premixed, Stainless Steel Fiber Mesh Burners

High-efficiency combustion and low pollutant levels of less than 20 ppm NOx.

Low Vent Temperature

Modest venting temperatures allow units to be common vented using eco-friendly PolyPro.

AERCO HeatSmart Sizing Tool

A Guaranteed Way to Size Your Water Heaters

AERCO's user-friendly HeatSmart sizing tool is a practical and financially viable alternative to measuring and monitoring flow for months to determine the design load conditions for optimum water heater sizing. AERCO HeatSmart is built upon 70 years of experience and empirical data from sizing and selecting instantaneous domestic water heaters across a variety of commercial building applications. Additionally, through its remote monitoring system, AERCO has visibility to numerous demand profiles for a variety of applications which allows HeatSmart to generate a much more realistic and economic selection proven to satisfy the specified load of your project without the excessive oversizing prevalent with most industry-standard sizing methods. By not oversizing your water heater, you'll save energy, optimize your system and increase return on investment. It also provides peace of mind by ensuring the AERCO generated sizing will meet the design load.

AERCO is the only manufacturer to guarantee its selection will satisfy the building design load provided the real design conditions and accurate fixture count have been entered to generate the sizing. The guarantee covers material and labor charges necessary to correct the system capacity issue.

The comprehensive tool gives you a high degree of flexibility during sizing and selection process allowing you to:

- Size a system using building fixture count or input GPM
- Size a single system with multiple applications (e.g., a resort with multiple full service restaurants)
- Size multiple systems (or zones) within a single building
- Size multiple systems (or zones) within a single building with multiple applications
- Size a campus with multiple building with multiples zones and/or multiple applications
- As an option, incorporate storage tanks into the design
- Calculate and incorporate the stored water volume within the piping
- Add desirable spare or redundant capacities
- Review previous sizing reports ran with or without sizing guarantee

Every sizing will generate a PDF of the selection report for print or download. You can access HeatSmart at heatsmart.aerco.com.

The guaranteed HeatSmart sizing will ensure the best-sized gas-fired water heater for your project!

Venting and Installation Advantages

Venting Versatility

The Innovation provides a number of venting options including sidewall, through-the-roof, and ducted combustion capabilities (direct-vent). It's also approved for venting with PVC, CPVC, Polypropylene, or AL29-4C materials.

Engineering Support

Customers can also leverage the vast experience of AERCO engineers who have devoted their careers to developing cost- and space-saving solutions. Standard services available include:

- AERCO engineers work with manufacturers to verify vent sizing/design for enhanced reliability
- AutoCAD drawings
- Submittal information
- Customer service

Vent Configurations

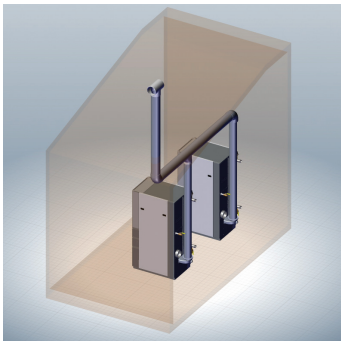

Common vertical vent/room air

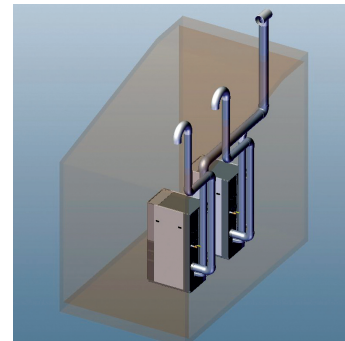

Common vertical vent/
individual vertical air

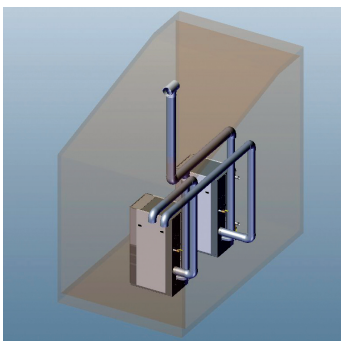

Common vertical vent/
individual sidewall air

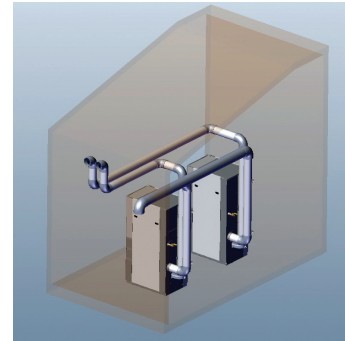

Individual sidewall vent/
common sidewall air

Specifications and Dimensions

	INN 600N	INN 800N	INN 1060N	INN 1350N
Adjustable Temperature Control	50°F to 190°F	50°F to 190°F	50°F to 190°F	50°F to 190°F
Ambient Temperature	0°F to 130°F	0°F to 130°F	0°F to 130°F	0°F to 130°F
Accuracy	+/-4°F	+/-4°F	+/-4°F	+/-4°F
Input	625 MBH (Natural Gas or Propane)	800 MBH (Natural Gas or Propane)	1,060 MBH (Natural Gas or Propane)	1,350 MBH (Natural Gas or Propane)
Certified Efficiency (DOE 10 CFR Part 431)	93%	94%	95%	96%
Turndown Ratio (up to)	12:1	16:1	21:1	27:1
Flue Size	6" Diameter	6" Diameter	6" Diameter	6" Diameter
Flue Material (per local code)	PVC, CPVC, PP or AL29-4C	PVC, CPVC, PP or AL29-4C	PVC, CPVC, PP or AL29-4C	PVC, CPVC, PP or AL29-4C
Water Inlet and Outlet	2" NPT Male	2" NPT Male	2" NPT Male	2" NPT Male
Gas Connection	1.5" NPT Male	1.5" NPT Male	1.5" NPT Male	1.5" NPT Male
Gas Pressure Requirements	14" WC Max; 4" WC Minimum @ Full Load (Natural Gas), 11" WC Minimum @ full load (Propane)	14" WC Max; 4" WC Minimum @ Full Load (Natural Gas), 11" WC Minimum @ full load (Propane)	14" WC Max; 4" WC Minimum @ Full Load (Natural Gas), 11" WC Minimum @ full load (Propane)	14" WC Max; 4" WC Minimum @ Full Load (Natural Gas), 11" WC Minimum @ full load (Propane)
Maximum Continuous Water Flow	50 GPM	50 GPM	50 GPM	50 GPM
Condensate Connection	3/4" NPT Female	3/4" NPT Female	3/4" NPT Female	3/4" NPT Female
Maximum Condensate Flow	4.5 GPH	6 GPH	8 GPH	11 GPH
Pressure Rating	160 PSIG @ 210°F	160 PSIG @ 210°F	160 PSIG @ 210°F	160 PSIG @ 210°F
NOx Emissions Certifications	SCAQMD, TCEQ	SCAQMD, TCEQ	SCAQMD, TCEQ	SCAQMD, TCEQ
Standard Listing and Approvals	UL, cUL, ASME (HLW)	UL, cUL, ASME (HLW)	UL, cUL, ASME (HLW)	UL, cUL, ASME (HLW)
Gas Train Options	FM Compliant	FM Compliant	FM Compliant	FM Compliant
Electrical Requirements	120VAC, Single Phase, 60 Hz 20 Amp (11 FLA)	120VAC, Single Phase, 60 Hz 20 Amp (11 FLA)	120VAC, Single Phase, 60 Hz 20 Amp (11 FLA)	120VAC, Single Phase, 60 Hz 20 Amp (11 FLA)
Water Pressure Drop @ 15 gpm	1.25 psi	1.25 psi	1.25 psi	1.25 psi
Water Pressure Drop @ 30 gpm	2 psi	2 psi	2 psi	2 psi
Water Volume	25.3 gallons	24.3 gallons	22.0 gallons	19.9 gallons
Weight, Installed	980 lbs (dry), 1,202 lbs (wet)	980 lbs (dry), 1,202 lbs (wet)	1,000 lbs (dry), 1,190 lbs (wet)	1,050 lbs (dry), 1,222 lbs (wet)
Weight, Shipping	1,080 lbs	1,080 lbs	1,100 lbs	1,150 lbs

Innovation	Depth	Width	Height
600/ 800/ 1060/ 1350	51"	28"	76"





Heating and Hot Water Solutions

AERCO International, Inc. • 100 Oritani Drive • Blauvelt, NY 10913
USA: T: (845) 580-8000 • Toll Free: (800) 526-0288 • AERCO.com

© 2020 AERCO