

MODULAR PANEL

TABLE OF CONTENTS

MODULAR PANEL SYSTEM

M-1	Description
M-2	General Specifications
M-3	Operation and Maintenance
M-4	System Design
M-5	Panel Outputs (Metric)
M-6	Panel Outputs (Imperial)
M-7	Modular - Imperial and Metric 6 Pass Panels
M-8	Modular - Imperial and Metric 5 and 10 Pass Panels
M-9	Piping Details For Modular Panels
M-10	Modular Panel at Perimeter Wall in T-Bar Ceiling
M-11	Framed Modular Panel in Gyproc Ceiling
M-12	Surface Mounted Modular Panel
M-13	Supply, Return Connection and Expansion Details For Modular Panels
	Radiant Panel Installation Instructions



Twa Panel Systems, Inc.

FRENGER.

MODULAR PANEL

DESCRIPTION

Modular panels are an easily installed type of radiant heating panel. The modular panel is typically supported by an exposed grid acoustic ceiling system. Modular panels are manufactured to suit either metric or imperial ceiling grids with standard or tegular edges. Modular panels supported by an acoustic ceiling grid system are often silk-screened to simulate adjacent acoustic tiles. However, panels in gyproc ceilings are provided in a standard white finish. Panels can be provided with aluminum or steel frames for recess or surface mounting in areas other than acoustic ceiling grids. The panel comprises a serpentine copper coil mechanically attached to either an aluminum or steel tray. The active or radiating surface of the panel can also be perforated for reduced sound or noise transmission when used in a total ceiling arrangement.

ADVANTAGES

The modular format of the panel allows for zone or spot heating in an integrated building system. Panels are easily removed if dividing walls are moved and relocated.

APPLICATIONS

Modular panels are ideal for hospitals, nursing homes, daycare, commercial office developments, schools, museums, security facilities, airports, churches, banks, condominiums, laboratories, swimming pools, factories and workshops.

DESCRIPTION		
 Twa Panel Systems, Inc.	FRENGER.	M-1

MODULAR PANEL

GENERAL SPECIFICATIONS

Material Specification

Modular panels are a system of standard sized radiant panels which can be integrated into a suspended ceiling to provide overhead radiant heating.

The system can be used with hot water at various temperatures; insulation blankets with a heat reflecting foil backing are utilized to maintain heating efficiency.

The panels are fabricated from either 18 gauge aluminum sheet or 24 gauge steel sheet to which a heating coil is mechanically fastened. Thermal contact between the coil and panel is maintained by an aluminum heat saddle fastened with welded aluminum or steel studs. The coil is clipped to the heat saddle using cadmium plated steel clips where heat transfer paste is used at the interface between the aluminum heat saddle and both the face of the panel and the tubing.

Dimensions and Weight

Modular panels are available in the following sizes:

Imperial: 24" x 24", 24" x 48", 48" x 48", 24" x 60"

Metric: 600mm x 600mm, 600mm x 1200mm,
1200mm x 1200mm, 500mm x 1500mm,
600mm x 1500mm.

The working weight for the aluminum panels is approximately 7.5 kg/m² (1.5 lb/ft²)

The working weight for the steel panels is approximately 11.0 kg/m² (2.2 lb/ft²)

Materials of Construction

- Pipework: Each panel has its own serpentine pipe coil of 16 mm (5/8") O.D. tubing.
- Panels: 1 mm (0.040") aluminum or 0.61 mm (0.027") steel sheet with standard square edges or tegular edge detail.
- Paint finish: Standard finish is off-white or silk-screen printed to simulate adjacent acoustic ceiling tiles.
- Contact strips: Aluminum heat saddle bolted to the back of the panel using steel or aluminum studs which are welded to the panel.
- Insulation: As specified by consultant's specification, usually a minimum of 25 mm (1") thick foil back batt insulation.

GENERAL SPECIFICATIONS



Twa Panel Systems, Inc.

FRENGER.

M-2

MODULAR PANEL

OPERATION AND MAINTENANCE

Modular panels are incorporated into a building's heating/cooling system and will remain trouble free provided the following procedures are followed and inspections performed during start up and maintenance.

Operation

Heating mains should be flushed prior to connection to the radiant panels. After connection, the hydronic system should be flushed again and then dry pressure tested to isolate any leaks. Any remaining air should be vented from the system and boiler temperature should be brought up gradually.

Maintenance

Apart from cleaning any strainers, little maintenance should be required on the pipework system. Any descaling of pipework should be carried out in the same way as for other hydronic heating systems. The panels are robust and should resist damage. If for some reason a panel has been damaged the pipework should be inspected to ensure that the aluminum studs, pipe saddles or pipe clips have not been displaced or dislodged.

Cleaning

The surface of modular panels is best cleaned using an industrial vacuum cleaner to remove dust. However, if the panels become soiled they can be cleaned using a damp cloth and mild detergent.

OPERATION AND MAINTENANCE



Twa Panel Systems, Inc.

FRENGER.

M-3

SYSTEM DESIGN

Radiant panel system design is fundamentally similar to that of other perimeter heating systems. The design procedure is as follows:

1. Perimeter heat losses for the space are calculated using standard ASHRAE methods and good engineering practice.
2. Water temperature drop across the panel system is calculated based on flow rate, hot water supply temperature and required heat output:

$$\Delta T = \frac{\text{Heat loss}}{\text{Flow rate} \times \text{Heat capacity}}$$

Where ΔT is in $^{\circ}\text{C}$

Heat loss is in Watts

flow rate is in kg/second

heat capacity is in $\text{J}/(\text{kg} \cdot ^{\circ}\text{C})$

3. Mean water temperature is determined by subtracting half of the temperature drop from the hot water supply temperature

$$t = \text{hot water temp.} - (0.5 \times \Delta T)$$

4. Use the mean water temperature value (t) calculated in step 3 and the table on page M-5 to determine the heat output of the panel in watts per linear meter.
5. Determine the required panel width based on the output per panel determined in step 4.
6. Determine panel configuration to suit the room floorplan. The following rules of thumb should be considered:
 - try to supply 50 % of the total perimeter heat required (as calculated in step 1) within 1.0 m (39") of the perimeter wall.
 - design piping configuration such that the "hottest" water is always supplied closest to the perimeter wall.

Twa Panel Systems, Inc. provides a design consulting service. For assistance with non standard applications or for in-depth information regarding radiant panel system design please contact our engineering department.

SYSTEM DESIGN



Twa Panel Systems, Inc.

FRENGER.

M-4

MODULAR PANEL

MODULAR PANEL METRIC OUTPUTS

PASSES		6	6	10	5	5	5	6
PANEL DIM'S [mm]		600X600	600X1200	1200X1200	600X600	600X1200	500X1500	600X1500
M E A N W A T E R T E M P E R A T U R E (°C)	48.9	94	188	376	79	158	212	255
	51.7	111	222	444	85	170	236	284
	54.4	129	258	516	94	188	258	311
	57.2	138	276	552	103	206	282	340
	60.0	147	294	588	111	222	304	367
	62.8	158	316	632	120	240	328	396
	65.6	170	340	680	129	258	352	425
	68.3	182	364	728	141	282	375	452
	71.1	194	388	776	152	304	400	481
	73.9	205	410	820	164	328	425	510
	76.7	217	434	868	176	352	451	540
	79.4	229	458	916	188	376	477	572
	82.2	246	492	984	199	398	502	619
	85.5	258	516	1032	211	422	527	654
	87.8	270	540	1080	226	452	549	689
	90.6	287	574	1148	240	480	571	718
93.3	305	610	1220	255	510	596	754	
96.1	323	646	1292	271	542	621	789	
98.9	340	680	1360	281	562	646	824	

Outputs expressed in WATTS/Panel, based on 21°C room temperature.

PANEL OUTPUTS (METRIC)



Twa Panel Systems, Inc.

FRENGER.

M-5

MODULAR PANEL

MODULAR PANEL IMPERIAL OUTPUTS

PASSES		6	6	10	5	5	5
PANEL DIM'S [feet]		2x2	2x4	4x4	2x2	2x4	2x5
M E A N W A T E R T E M P E R A T U R E (°F)	120	320	640	1280	270	540	870
	125	380	760	1520	290	580	970
	130	440	880	1760	320	640	1060
	135	470	940	1880	350	700	1160
	140	500	1000	2000	380	760	1250
	145	540	1080	2160	410	820	1350
	150	580	1160	2320	440	880	1450
	155	620	1240	2480	480	960	1540
	160	660	1320	2640	520	1040	1640
	165	700	1400	2800	560	1120	1740
	170	740	1480	2960	600	1200	1840
	175	780	1560	2120	640	1280	1950
	180	840	1680	3360	680	1360	2110
	185	880	1760	3520	720	1420	2230
	190	920	1840	3680	770	1540	2350
	195	980	1960	3920	820	1640	2450
	200	1040	2080	4160	870	1740	2570
	205	1100	2200	4400	925	1850	2690
	210	1160	2320	4640	960	1920	2810

Outputs expressed in BTUH/Panel, based on 70 F room temperature.

Derate 7% for perforated panels.

PANEL OUTPUTS (IMPERIAL)



Twa Panel Systems, Inc.

FRENGER.

M-6

MODULAR PANEL

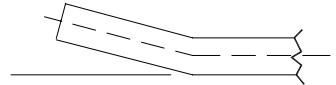
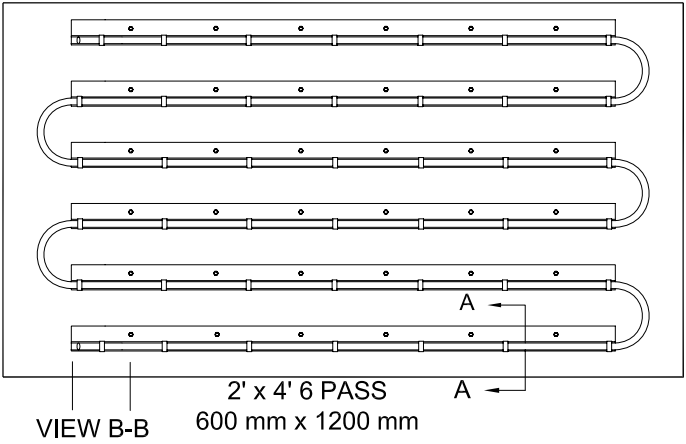

VIEW B-B

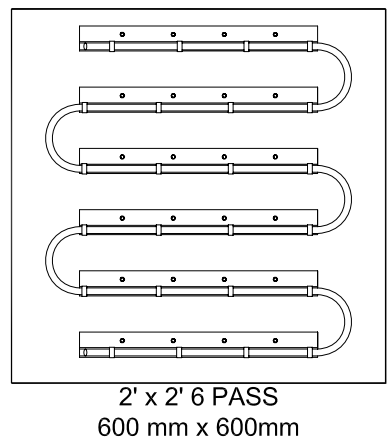
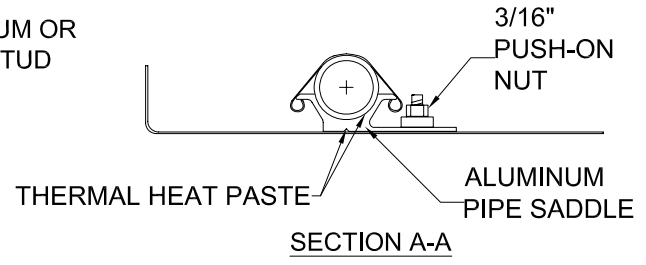
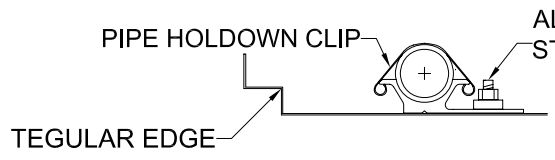

MODULAR - IMPERIAL & METRIC 6 PASS PANELS		
Twa Panel Systems, Inc.	FRENGER.	M-7

MODULAR PANEL

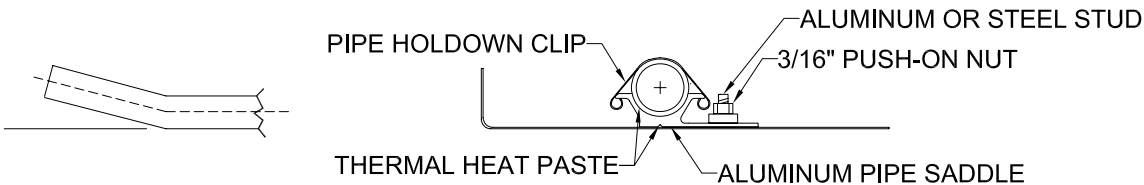
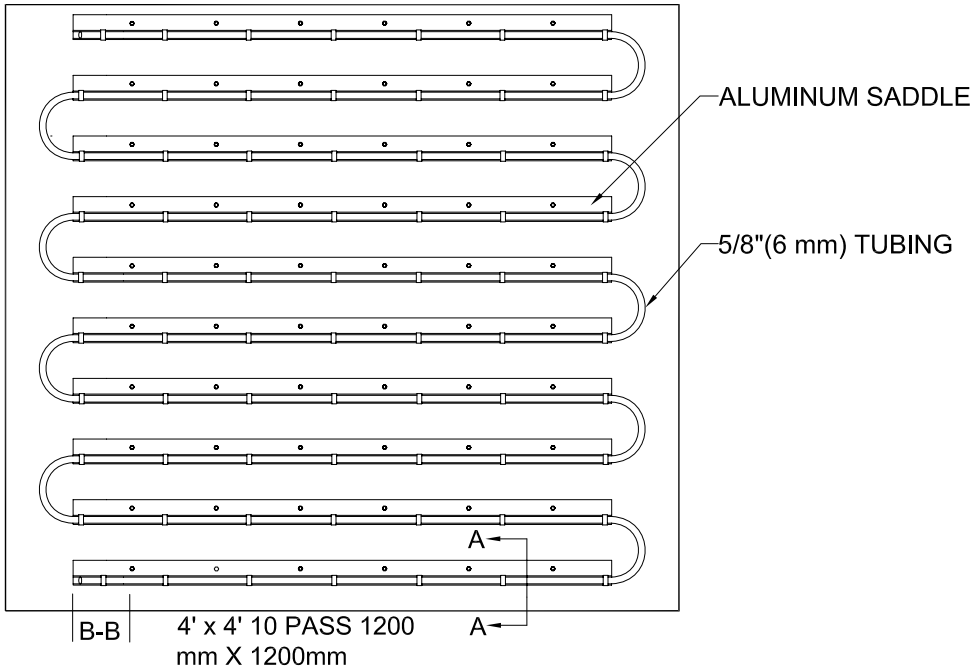

VIEW B-B

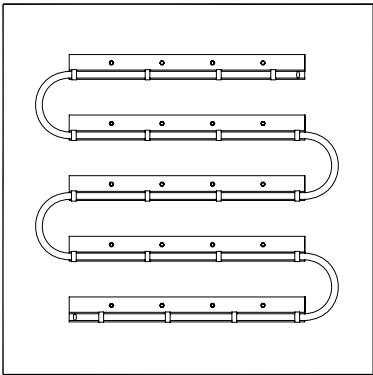

2' x 2' 5 PASS
600 mm x 600mm

SECTION A-A

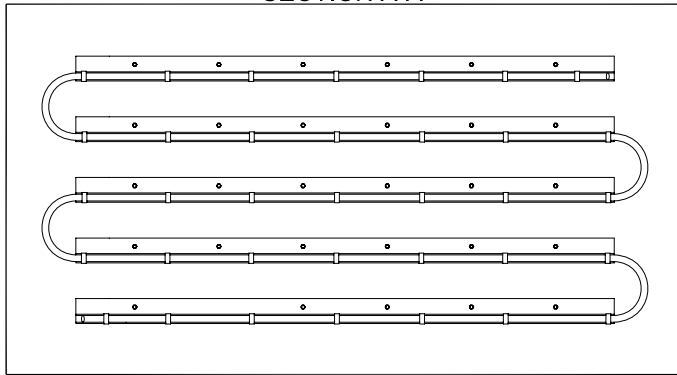

2' x 4' 5 PASS
600 mm x 1200mm

MODULAR - IMPERIAL & METRIC 5 & 10 PASS PANELS



Twa Panel Systems, Inc.

FRENGER.

M-8

MODULAR PANEL

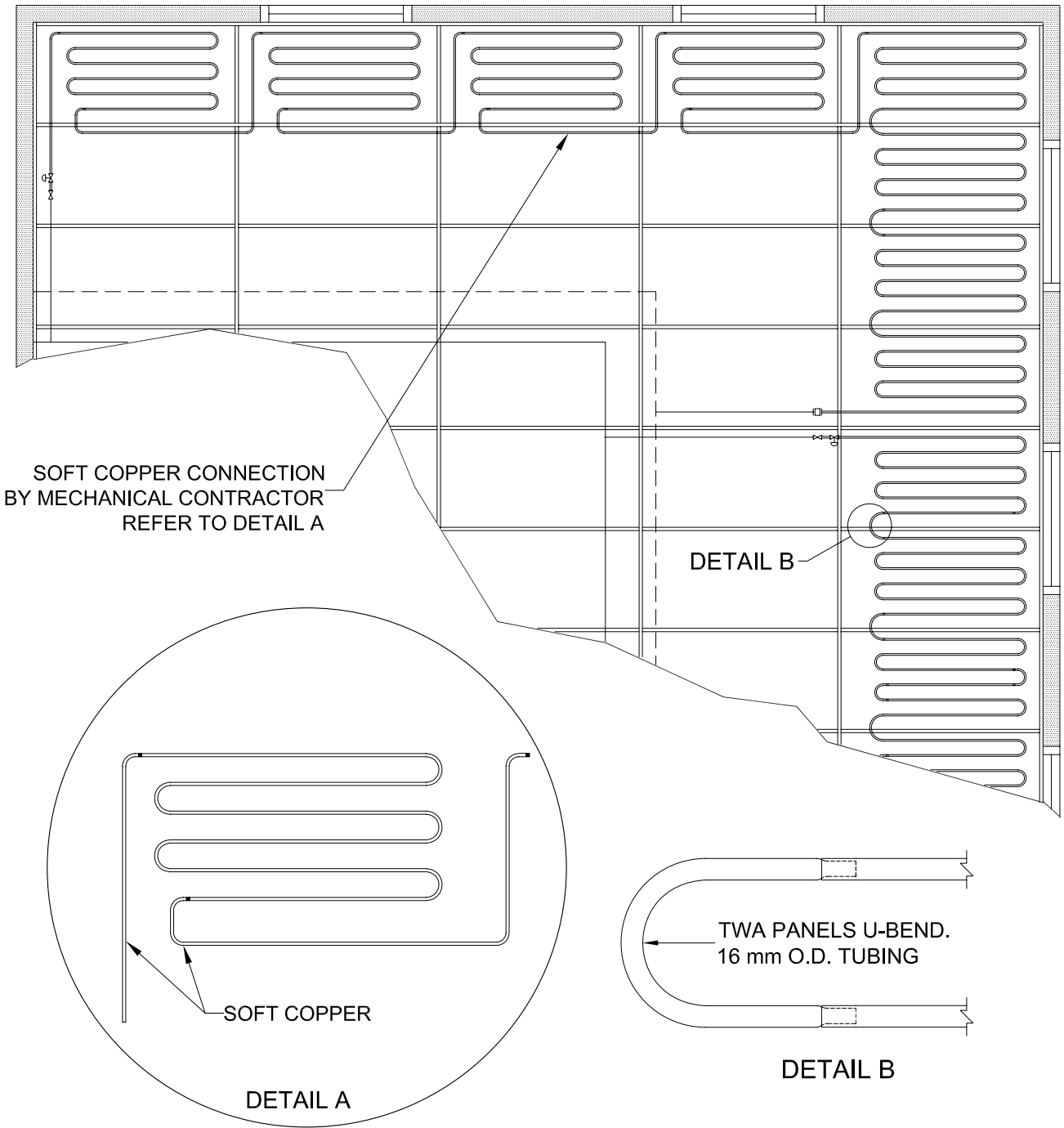

PIPING DETAILS FOR MODULAR PANELS



Twa Panel Systems, Inc.

FRENGER.

M-9

MODULAR PANEL

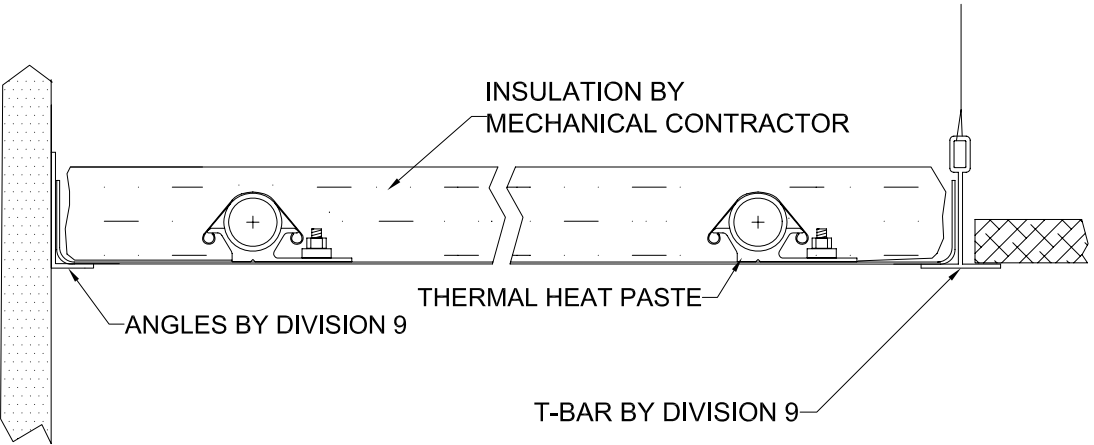
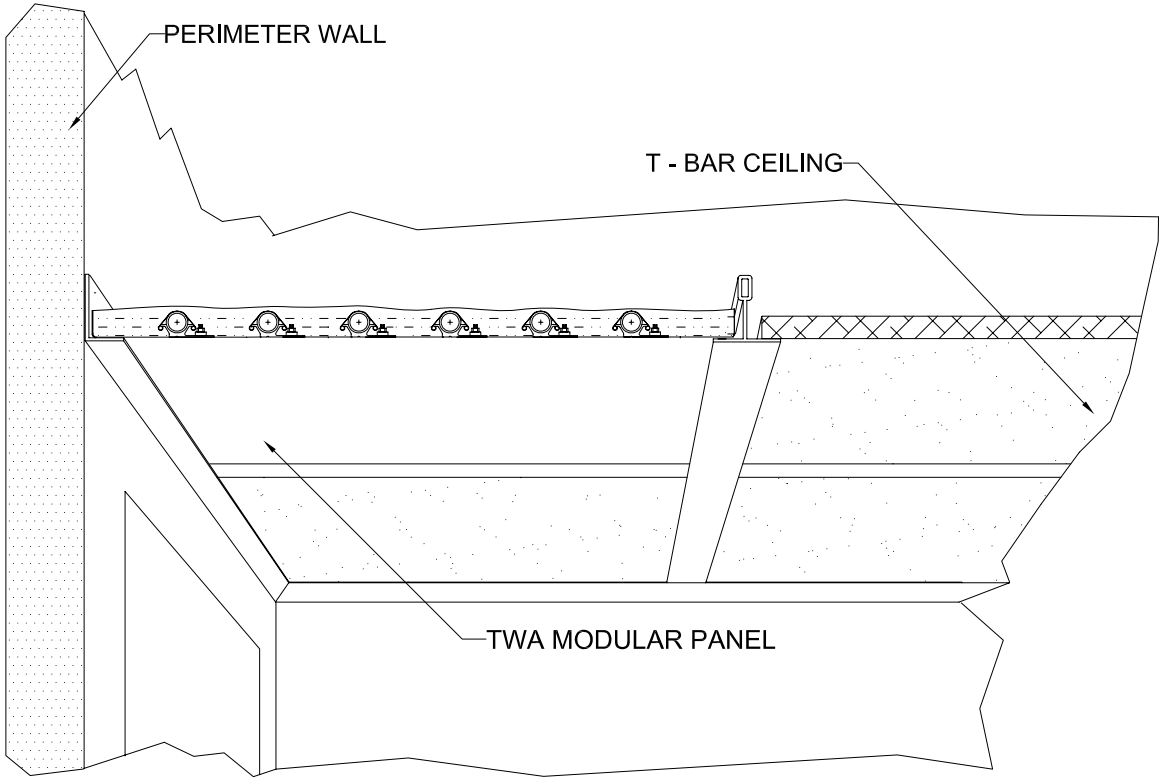

MODULAR PANEL AT PERIMETER WALL IN T-BAR CEILING



Twa Panel Systems, Inc.

FRENGER.

M-10

MODULAR PANEL

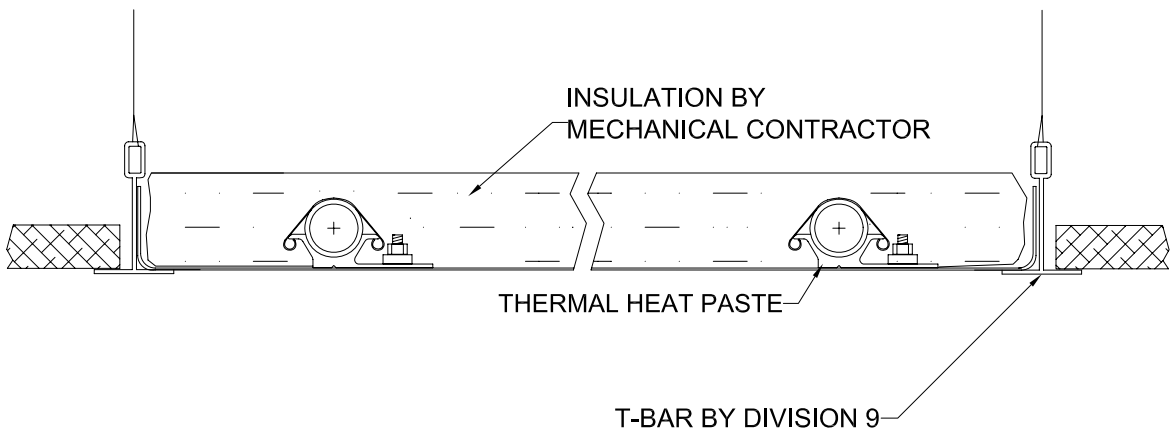
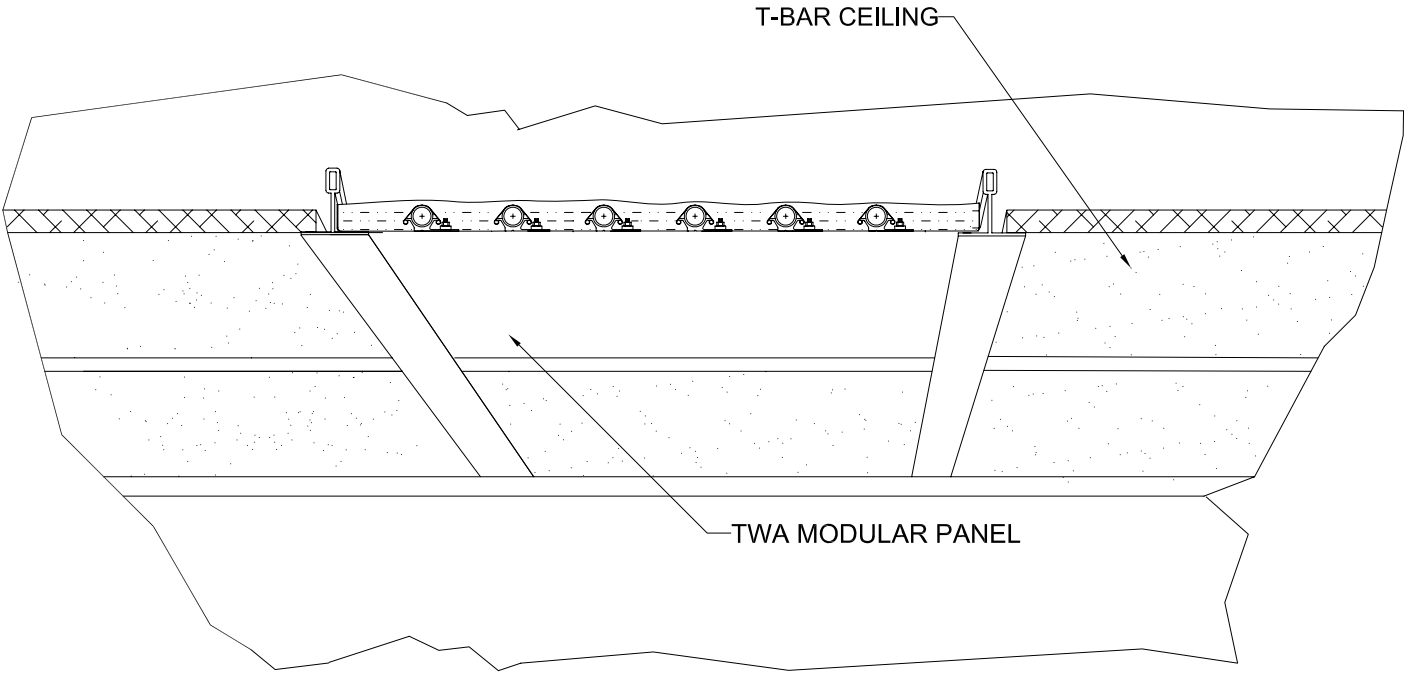

MODULAR PANEL IN T-BAR CEILING		
 Twa Panel Systems, Inc.	FRENGER.	M-10a

MODULAR PANEL

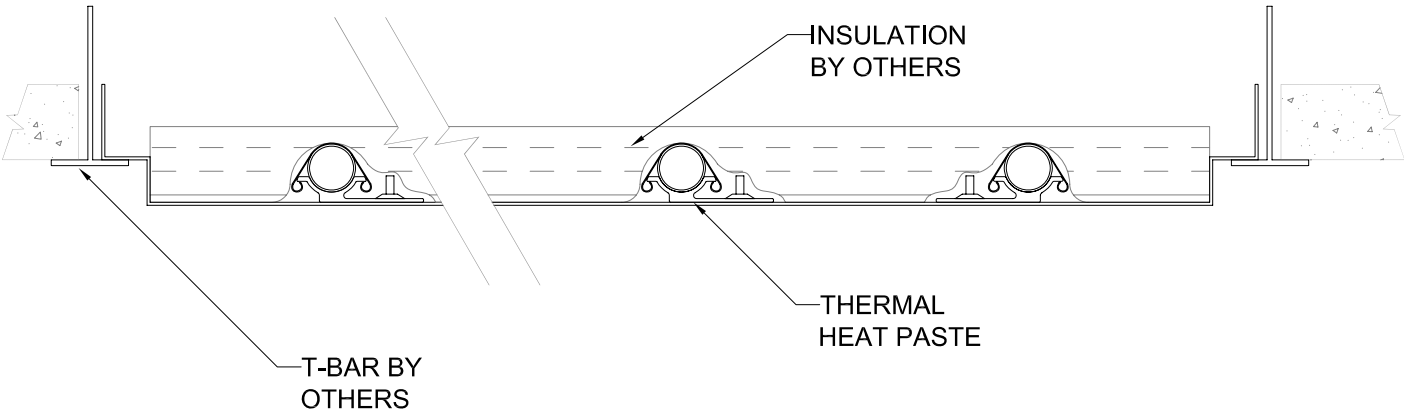
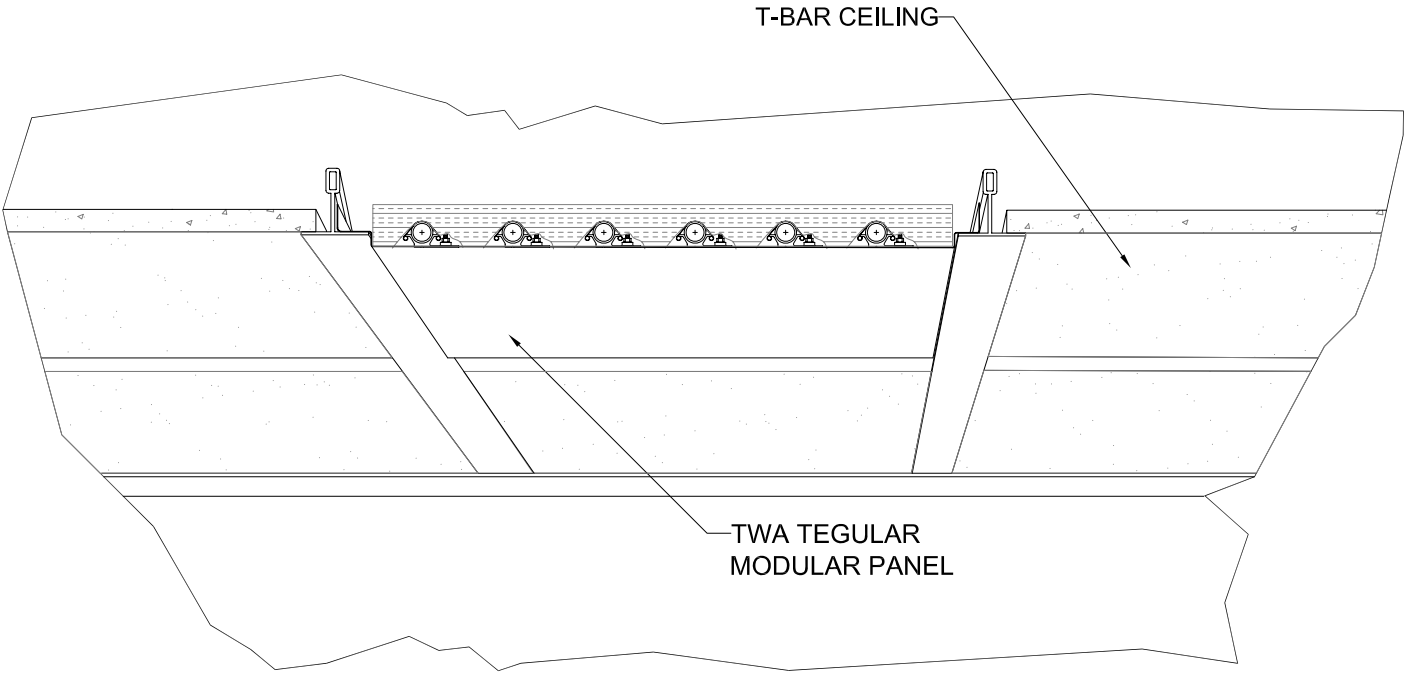

TEGULAR MODULAR PANEL IN T-BAR CEILING



Twa Panel Systems, Inc.

FRENGER.

M-10b

MODULAR PANEL

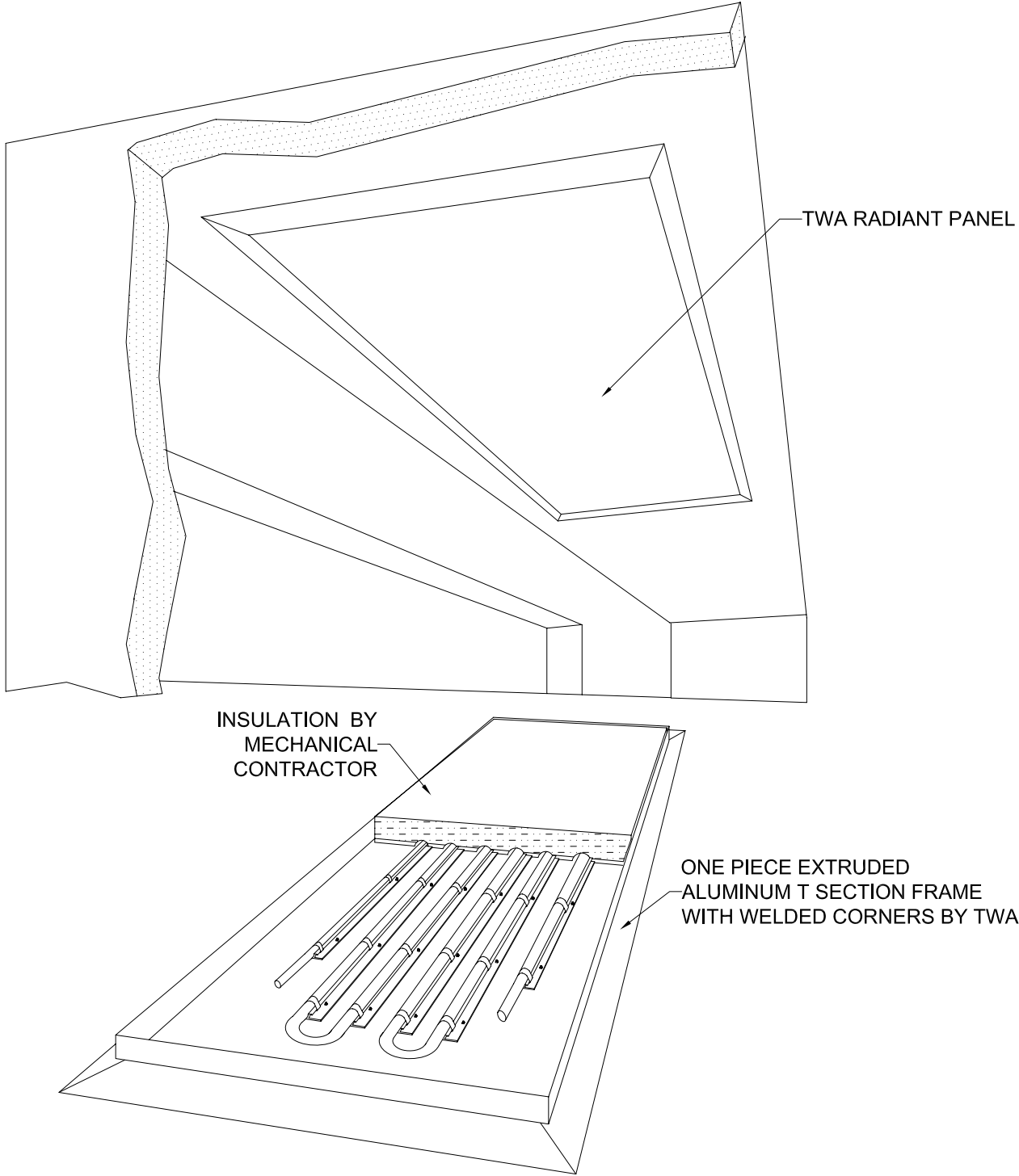

FRAMED MODULAR PANEL IN GYPROC CEILING

 **Twa Panel Systems, Inc.**

FRENGER.

M-11

MODULAR PANEL

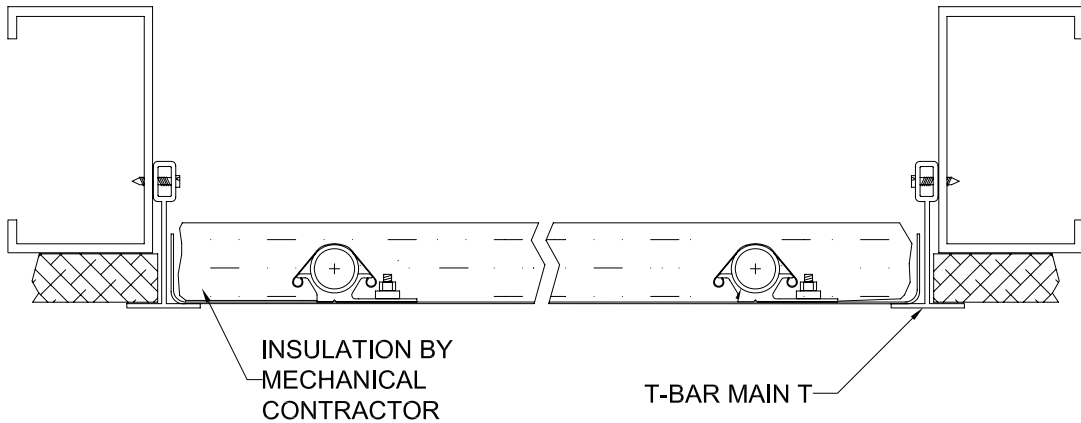
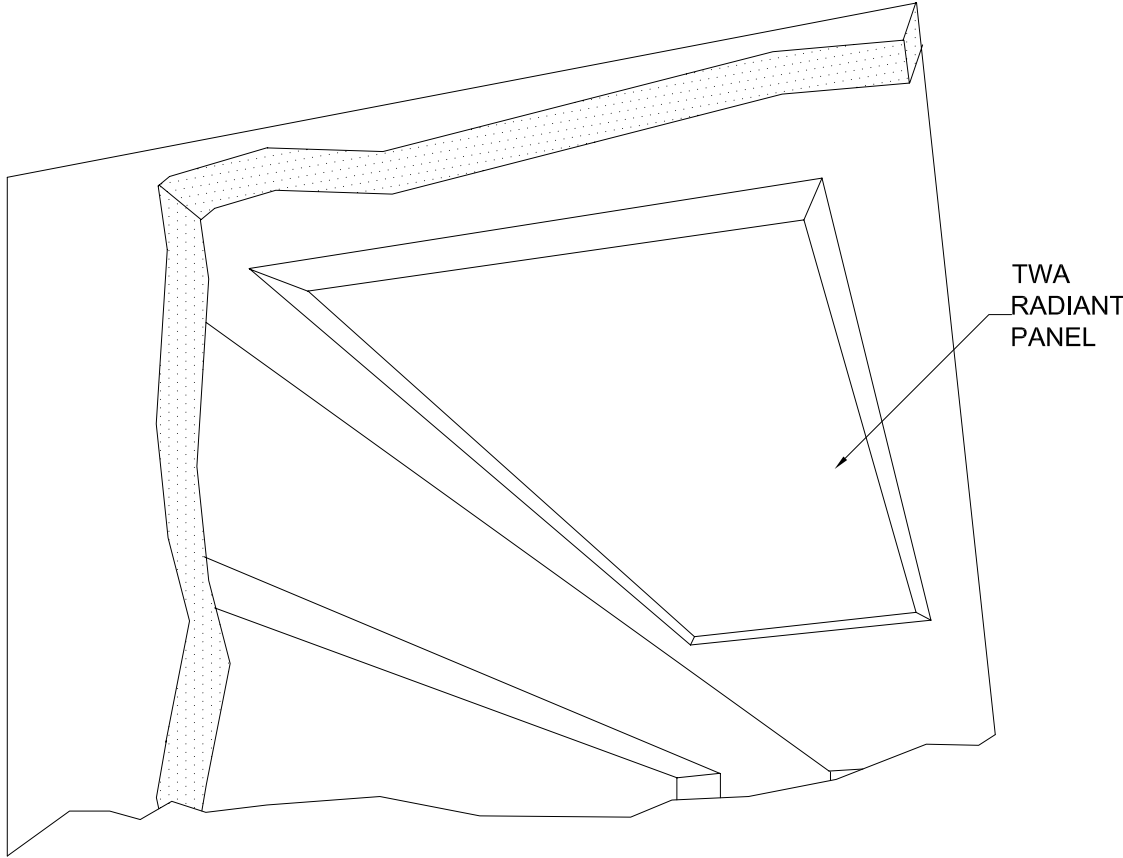

NOTE: IF SPACE ABOVE PANEL NOT ACCESSIBLE, REMOTE ACCESS PANEL REQUIRED FOR PANEL CONNECTION.

FRAMED MODULAR PANEL IN GYPROC CEILING		
 Twa Panel Systems, Inc.	FRENGER.	M-11-2

MODULAR PANEL

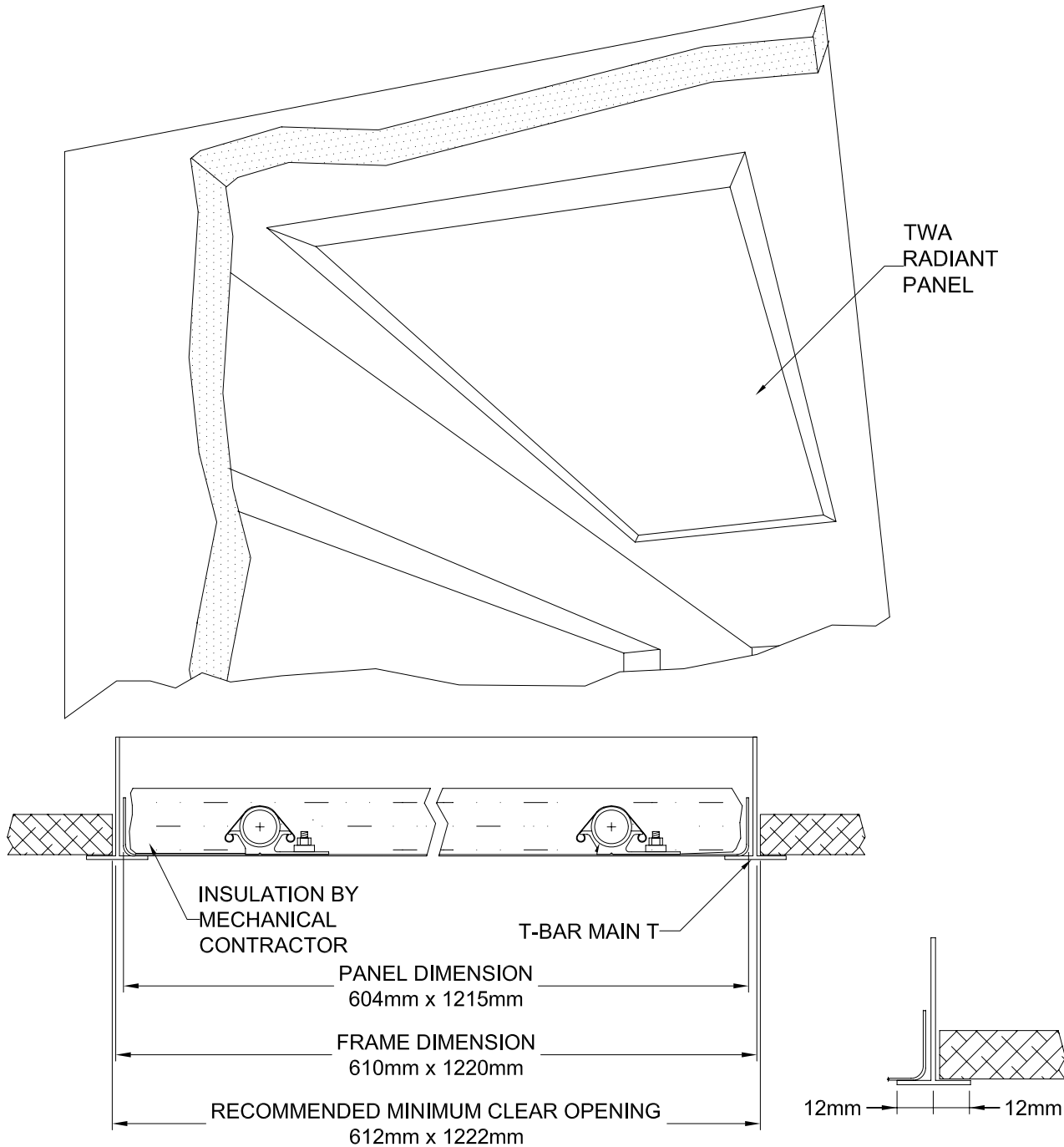

NOTE: IF SPACE ABOVE PANEL NOT ACCESSIBLE, REMOTE ACCESS PANEL REQUIRED FOR PANEL CONNECTION.

FRAMED MODULAR PANEL IN GYPROC CEILING		
Twa Panel Systems, Inc.	FRENGER.	M-11-3

LINEAR PANEL

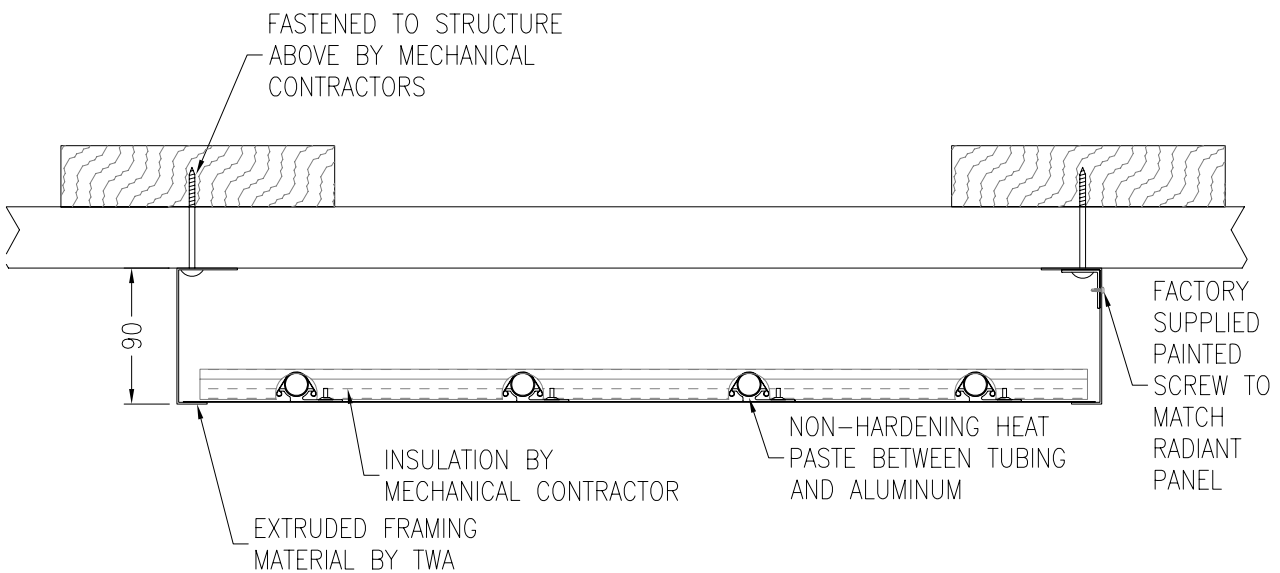
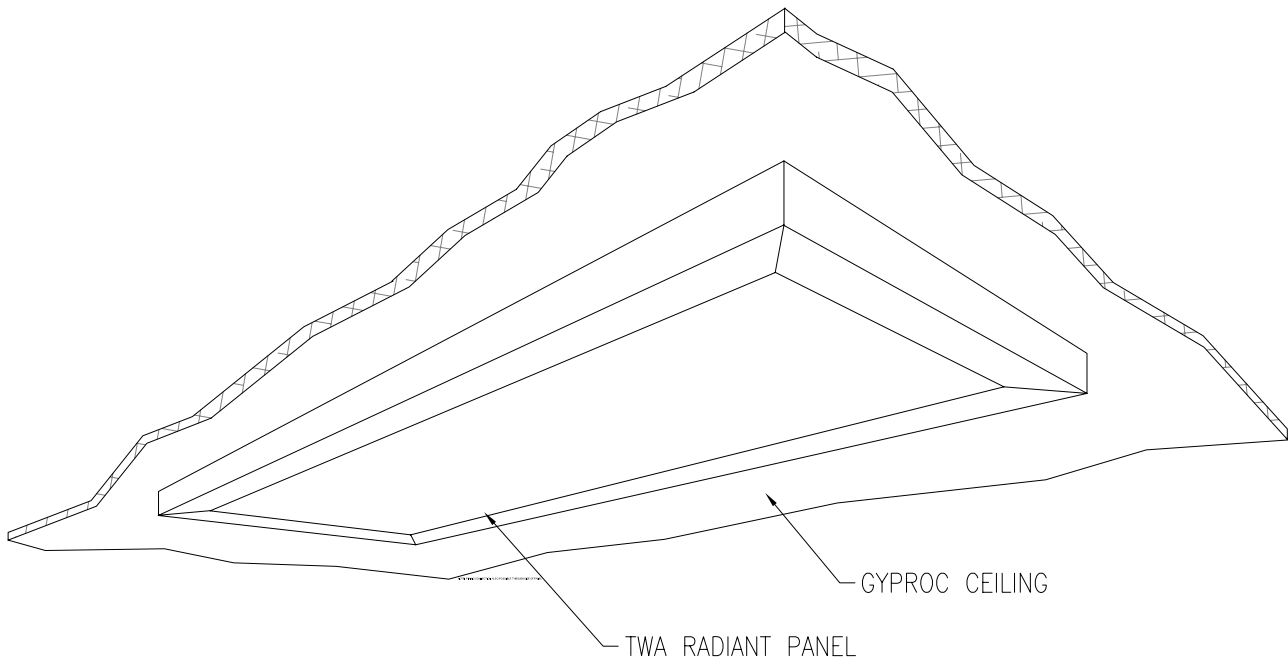

SURFACE MOUNTED MODULAR PANEL



Twa Panel Systems, Inc.

FRENGER.

M-12

MODULAR PANEL

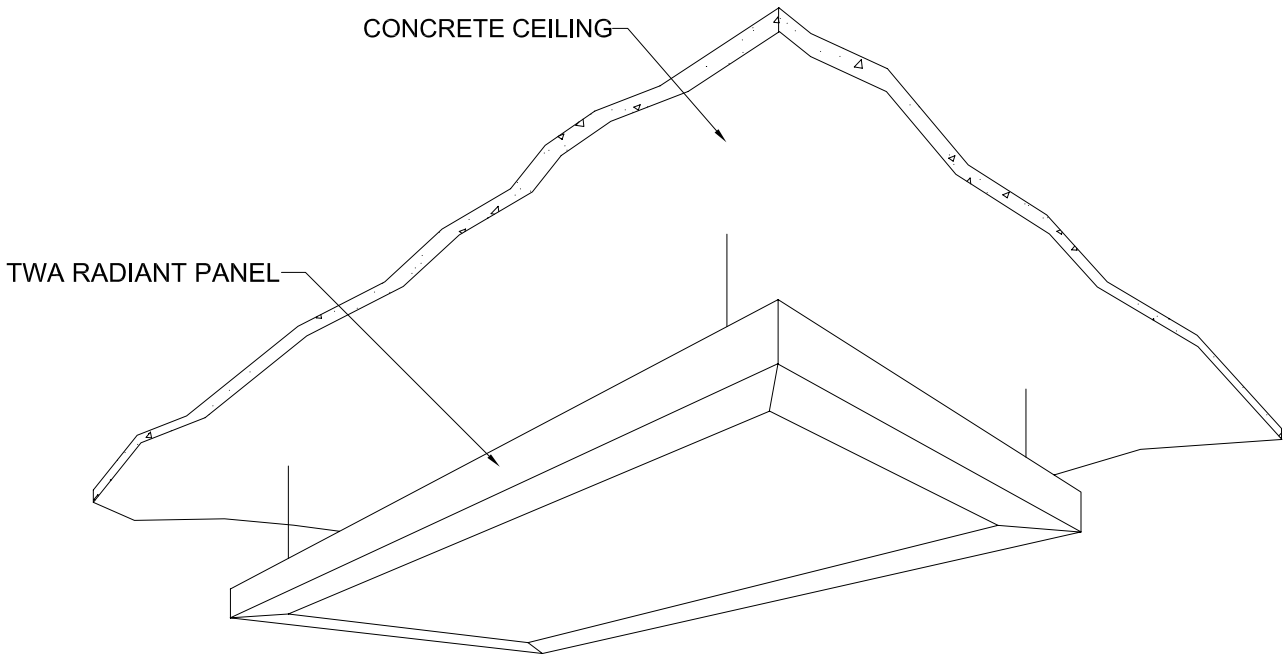

NOTE: PIPING CONNECTION ALSO POSSIBLE THROUGH SIDE OF PANEL.

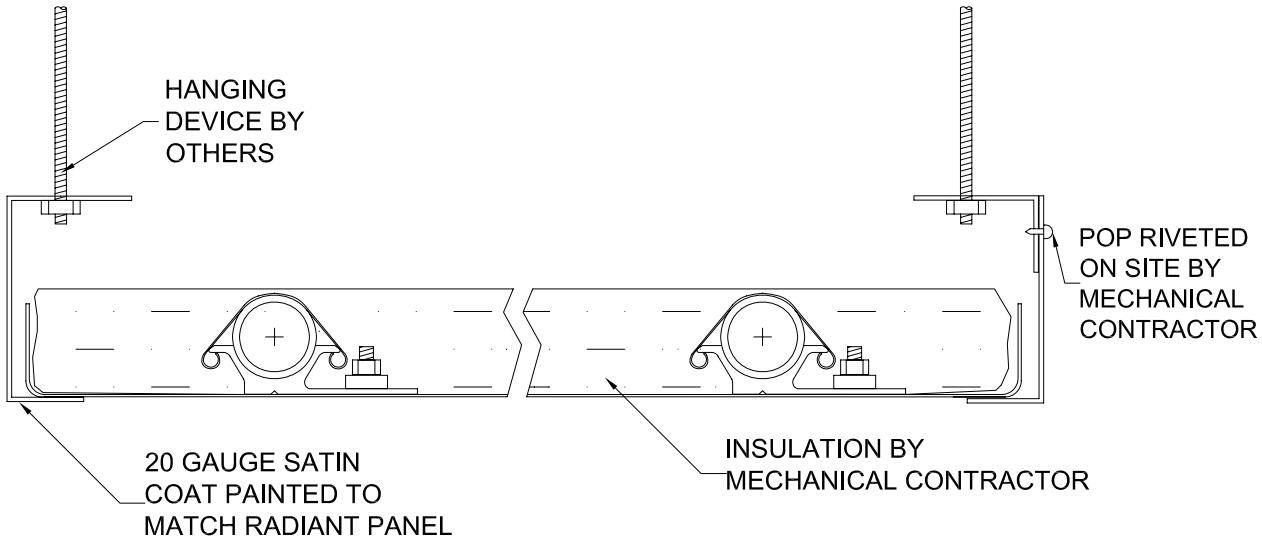

FREE HANGING MODULAR PANEL		
 Twa Panel Systems, Inc.	FRENGER.	M-12A

MODULAR PANEL

HOT WATER SUPPLY AT OUTSIDE WALL

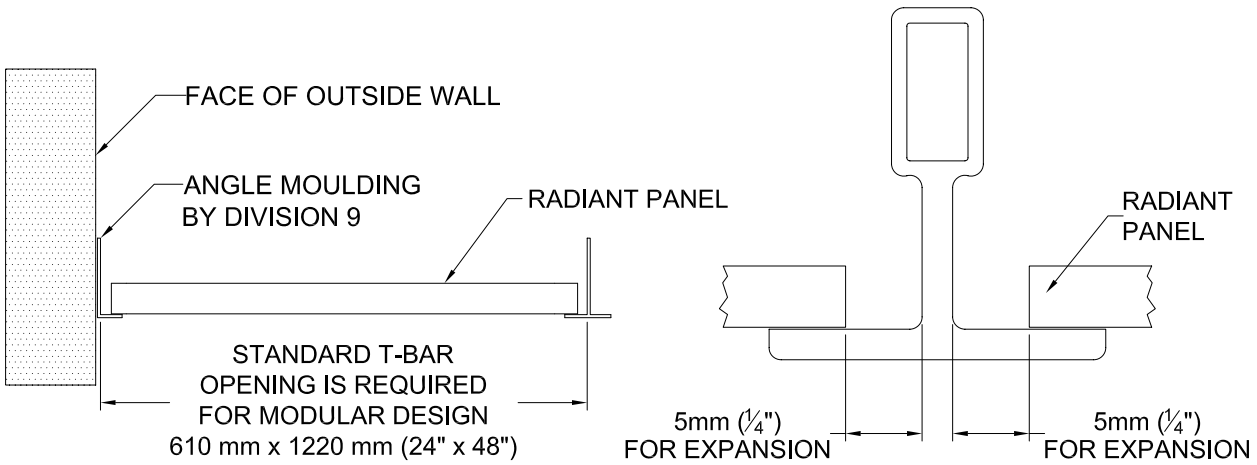
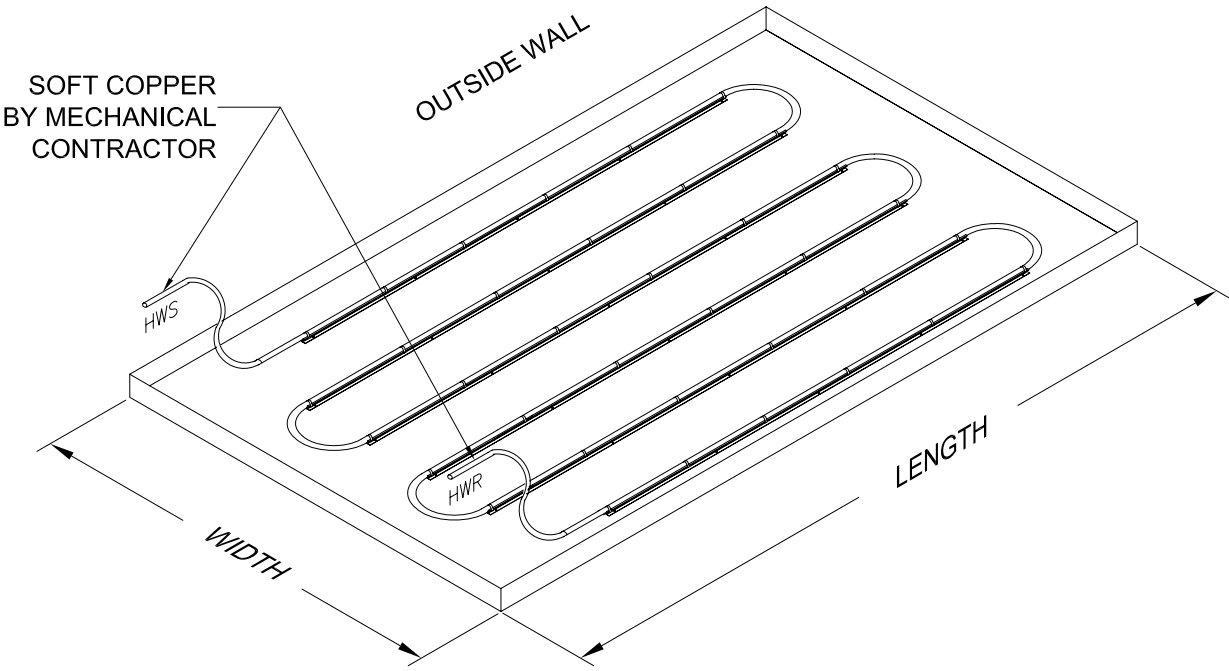

EXPANSION GAP DETAIL

SUPPLY, RETURN CONNECTION AND EXPANSION DETAILS		
 Twa Panel Systems, Inc.	FRENGER.	M-13

MODULAR PANEL

INSTALLATION INSTRUCTIONS

Twa Panel Systems, Inc. linear radiant heating panels are finished with standard white polyester powder coating. However, the panel surface must not come in contact with the bare skin. Perspiration or grease from an ungloved hand can potentially leave a mark on the panel.

INSTALLATION PERSONNEL MUST WEAR CLEAN WHITE GLOVES WHEN HANDLING THE RADIANT PANELS.

USE A HEAT PAD BETWEEN RADIANT PANEL AND COPPER PIPE WHEN MAKING SOLDER CONNECTION. EXCESSIVE HEAT CAN DAMAGE THE PAINT FINISH.

Thank you for your attention to these details.

RADIANT PANEL INSTALLATION INSTRUCTIONS		
 Twa Panel Systems, Inc.	FRENGER.	